

Preparation

This chapter presents basic information that is essential for the production of the KUKATE34. This information is specifically tailored to this system and must be read carefully.

Technical drawings, parts lists, tool lists, manufacturing instructions and the assembly instructions are coordinated with each other.

Numbering system

Since the numbering system is designed specifically for this work, it will be described in more detail in this Chapter

Figure 3 shows the representation of the numbering system. The first digit stands for the chapter and the second for the respective subchapter. The third number defines the component from the bill of material (parts lists). These can thus be picked out precisely. The parts lists can be found in the respective chapters or in Annex D.

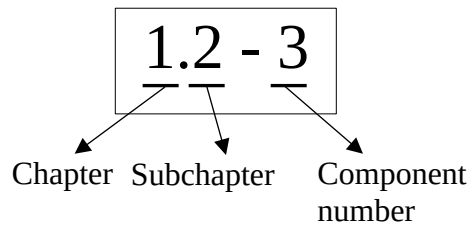

Figure 1 - Numbering system

Technical drawings

Drawing standards are drawn up according to fixed rules. In this section, the rules required for the OPEN-WINDMILL system are explained in more detail and the handling is shown as simply as possible

Sheet format

DIN 823 specifies the designation and sizes of the drawing sheets.

A0: 841 x 1189 mm

A1: 594 x 841 mm

A2: 420 x 594 mm

A3: 297 x 420 mm

A4: 210 x 297 mm

A5: 148 x 210 mm

Figure 2 shows the drawing sheets in relation to each other.

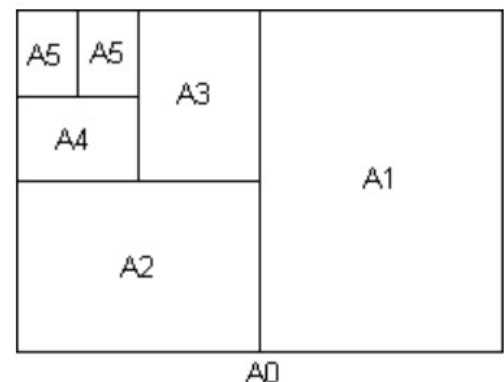

Figure 2 - Blade dimensions according to DIN 823

Scale

The dimensioning on the standardized technical drawings is important, as no scales or lengths are used in the construction manual. These can only be taken from the technical drawings. They are used to represent components in such way that the conditions are always given, even if they are reduced or enlarged. Drawings of life-size components have a scale of 1:1. **Figure 5** shows chessmen with a height of 50mm. These can easily be shown on a DIN A5 sheet on a scale of 1:1.

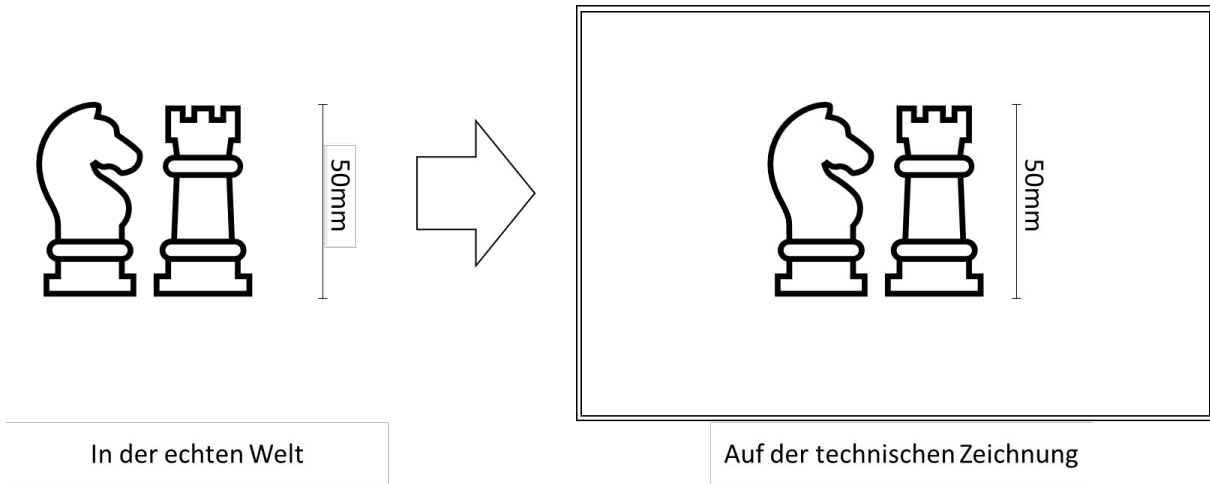

Figure 3 - Scale 1:1

Large components are displayed in reduced size. Figure 4 - Scale 1:50 shows the mast with a total

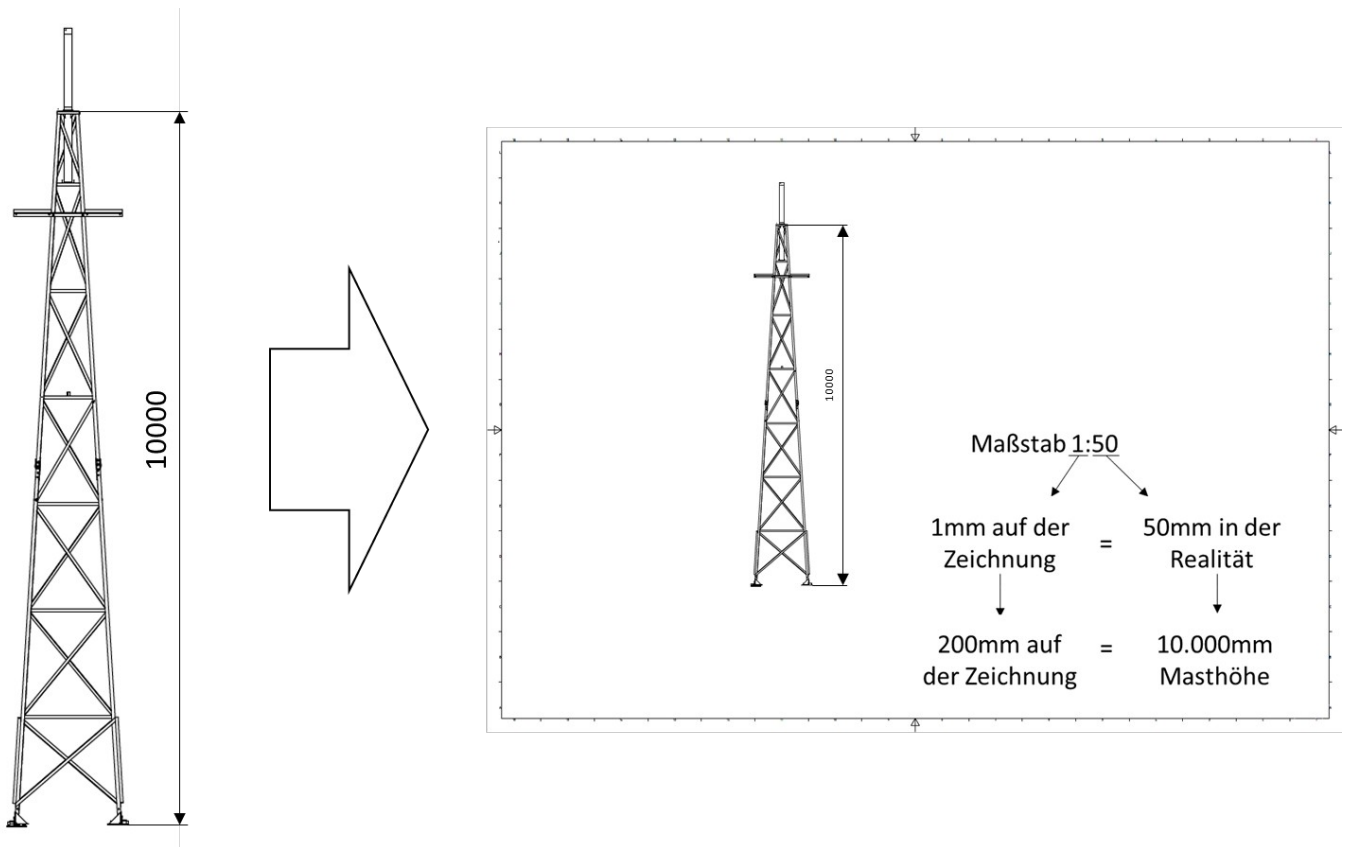

Figure 4 - Scale 1:50

height of 10m.

The drawing of the entire mast is too large for a DIN A4 sheet and is scaled appropriately to 1:50. If the real mast has a height of 10m = 10.000 mm, it will have a height of 200mm on the drawing. However, the displayed dimensioning must correspond to the real one. The scale must always be indicated on a technical drawing.

Computer printers only print drawings accurately under certain conditions. Often printers adapt the drawings to certain formats that do not resemble the original. For this reason, dimensions may only be measured and applied directly from drawings that exactly resemble the originals. Otherwise, the real dimension must be calculated using proportional calculation.

If a length dimensioned at 200mm is remeasured at 194mm on the print, measured dimensions must be increased by three percent for production. $200\text{mm}/100 = 2\text{mm}$ corresponding to 1%. Since the deviation is 3%, this results in a 6mm correction for the mast. All other measured lengths must be increased by 3%. Some printers even print different scales in x and y direction. Usually, all production dimensions are correctly indicated with numbers in mm lengths.

Lines according to DIN 15

In technical drawings the lines are of crucial importance. Each line type has its own use. [Table 2](#) shows the lines used in this work.





Line type	Line width	Image	Designation	Usage
Broad	0,5 mm		Full line	For visible edges and contours
Medium	0,35 mm		Dotted line	For concealed edges and outlines
Narrow	0,25 mm		Full line	Dimension lines, dimension auxiliary lines, hatching lines, surface characters, diagonal crosses, reference lines
Narrow	0,25 mm		Semi-dot line	Centre lines, pitch circles, bolt circles
narrow	0,25 mm		Freehand line	Break lines

Table 1 – Lines according to DIN 15

Drawing layer

This section explains how technical drawings are created from the body to the "production picture".

If you imagine a body that is irradiated with sunlight from above, for example, it casts a shadow on the ground. This shadow is caught on a drawing plane. (Fehler: Verweis nicht gefunden). Thus, you get the outline of the body from one side.

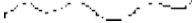
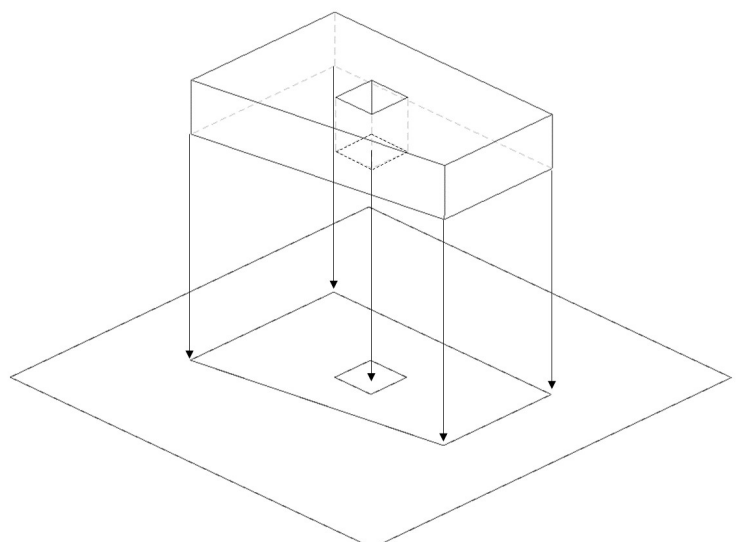

Figure 5 – Right-angled parallel projection

However, since this is only shown from one side, there is not enough information to see the whole body. Among other things, the thickness of the body is missing and "hidden edges" can also be lost. For this purpose, the body is rotated by 90° and projected backwards as shown in (Figure 6).

Since the body was only folded and not moved, the pixels of the edges that belong together still lie on a straight line: The corners A and A' coincide in the drawing plane in the first view. After folding, both are visible in the projection as end points of the line AA'.

The most significant view (shape, size, details) is usually defined as the front view. However, it can also be the production or use position of the workpiece.

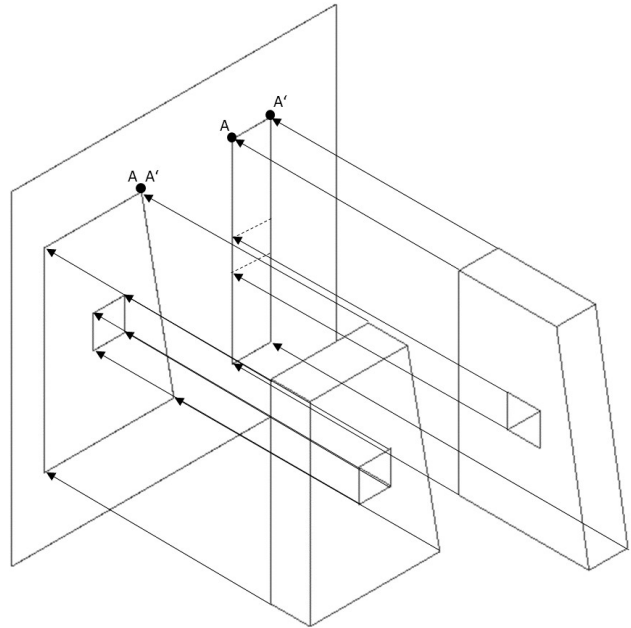

Figure 6 – Right-angled parallel projection with 90° rotation

Dimensioning system

To be able to manufacture a component, the dimensions are of decisive importance. In this work, the length dimensions are always in millimetres. The labelling is placed outside the body as far as possible.

Display in one view

Figure 7 shows the representation of a component in a one-dimensional view. The component shown is made from a plate of thickness $t = 2\text{mm}$. The "depth" of the component is therefore known and therefore only one view is required.

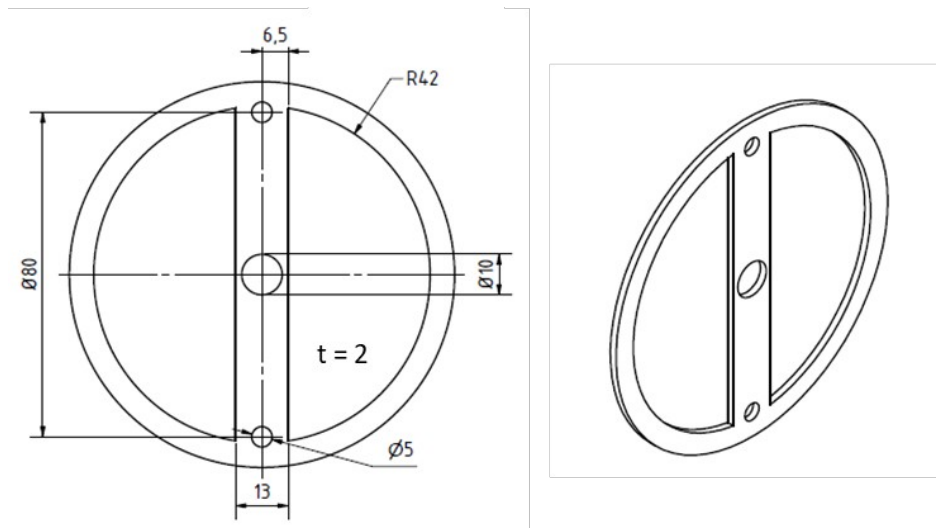

Figure 7 -One-dimensional representation

Display in two views

Figure 8 shows a component of which a second view is required. Otherwise, the position of the hole with a diameter of 6mm, for example, could not be determined.

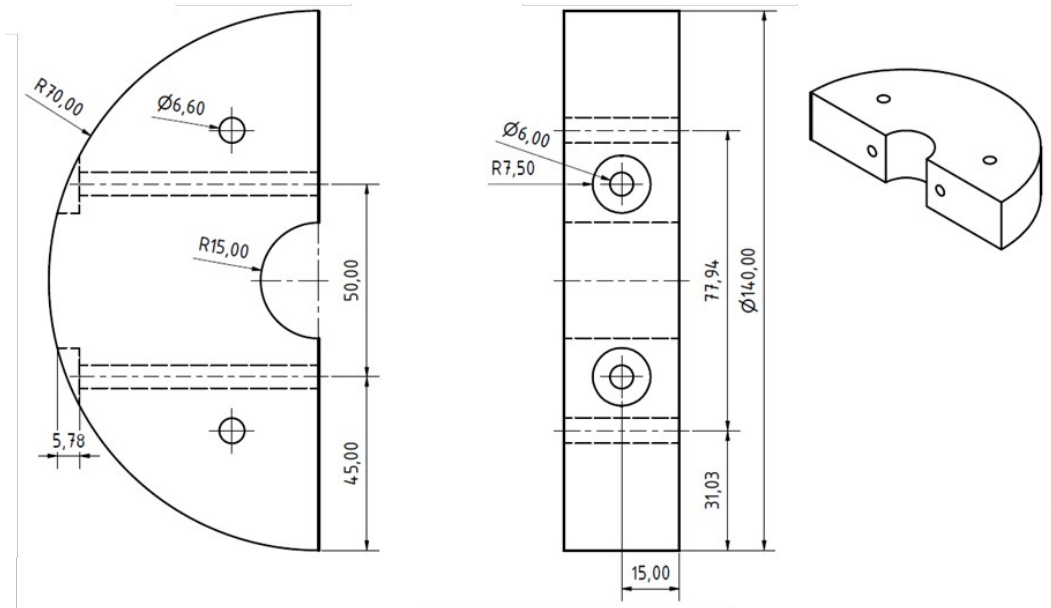

Figure 8 – Two-dimensional representation









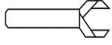

Symbols and dimensions of technical drawings

Symbol	Erklärung
	Beschreibt die Entfernung zwischen zwei Punkten. Die Angabe ist in Millimeter.
	Bohrungen oder Löcher können auf verschiedene Weise angegeben werden. Dies ist meist abhängig von der Ansicht oder der Vorliebe des Zeichners Ø – Durchmesser R – Radius
	Durch eine Mittellinie wird eine Bohrung in der Seitenansicht gekennzeichnet.
	Die Buchstaben deuten auf eine Detailansicht hin. Es sind immer 2 auf einer Zeichnung zu finden. Der erste Buchstabe ist auf der Kompletten Ansicht zu finden und der zweite in der Detailansicht. Die eingekreiste 4 steht für eine Positionsnummer. Die Nummer und das gezeigte Bauteil sind in der Teilleiste, auf der Zeichnung, wieder zu finden.
	Die Teilleiste zeigt alle verwendeten Baugruppen, Halbzeuge und Bauteile an. Kap. + Pos. - Die beiden Spalten ergeben die Bauteilnummer Pos. - Über die Position ist das Bauteil auf der Zeichnung wieder zu finden Bezeichnung - Gibt den Namen des Bauteils/ der Baugruppe an Norm - Die Norm wie z.B. DIN, EN oder ISO wird dort angegeben Anz. - Die verwendete Menge des jeweiligen Bauteils
	Schnittansichten werden durch zwei mit einem - verbundene Buchstaben angedeutet. Die Grundansicht zeigt durch eine Punkt-strich Linie und die beiden Buchstaben an welcher Stelle des Bauteils der Schnitt positioniert ist
	Das Symbol deutet auf eine Schweißnaht mit bestimmten Maßen hin. 2,5x2,5 - gibt die beiden Schänkel Längen der Schweißnaht an 2x - Anzahl der Schweißnähte 30 - ist die Länge der Schweißnaht (25) - gibt an wie viel Abstand zur nächsten Schweißnaht ist

Table 2 – Symbols and dimensions of technical drawings

Symbols and dimensioning of the construction manual

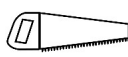
The construction manual uses a variety of symbols that describe the manufacturing process in more detail. The symbols used are shown and explained in Table 3.

Symbol	Explanation	To be considered
	<p>General tool kit</p> <ul style="list-style-type: none"> - This set contains tools, protective and auxiliary materials that are required for all work - The individual tools/aids are no longer listed in the instructions 	<p>The tool set contains the following tools / aids:</p> <p>Marking devices (centre punches, scribing needle, felt-tip pen, measuring devices, files, hammer, screw clamps)</p> <ul style="list-style-type: none"> - Work shoes, gloves, safety goggles, safety helmet
	<p>Drill</p> <ul style="list-style-type: none"> - Different types of drilling machines - Stand drilling machines should be used preferably - The size of the drills can be taken from the technical drawing - Diameter of the required drills is given 	<ul style="list-style-type: none"> - Before drilling, the holes are always marked. - Distances are measured with a measuring tool and marked with a marker (e.g. scribing needle). - Place the centre punch on the marked point and punch with a hammer - Speed of the drill is decisive. The speeds can be taken from Table 5 - After drilling, the holes are deburred with a file or countersink
	<p>Screwdriver/Wrench</p> <ul style="list-style-type: none"> - For tightening screws and nuts - Usually two are always required (for screw and nut) - Required spanner widths are specified according to ISO 	<ul style="list-style-type: none"> - Depending on the size and type of screw, the appropriate screwdriver must be selected - Permissible tightening torque must not be exceeded (Table 4)
	<p>Scissor</p> <p>For cutting materials. There are different types of shear for different materials</p>	
	<p>Marker</p> <p>Preferably use a scribing needle for marking materials</p>	
	<p>Measurement</p> <ul style="list-style-type: none"> - A wide variety of measuring tools are used. These are to be selected according to the required accuracy 	<ul style="list-style-type: none"> - Caliper - exactly accurate for the 0.1mm range - Ruler - exactly for the 1mm range - Measuring tape - for use with long lengths (>1m)
	<p>Compass</p> <ul style="list-style-type: none"> - For marking circles, radii and angles 	
	<p>Spirit level</p> <p>For aligning the components on a horizontal and vertical plane</p>	
	<p>Sawing</p> <ul style="list-style-type: none"> - Select saw depending on the material. It is preferable to use a stand saw (e.g. band saw or cold circular saw) <p>Angle grinders are suitable for work in which no fret saw can be used</p>	<ul style="list-style-type: none"> - The cuts are marked before sawing - Cutting waste of the saw must be considered - After sawing the edges are deburred with a file or angle grinder
	<p>Glue</p> <ul style="list-style-type: none"> - Bonding is described in chapter 0.4 	







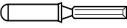
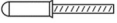

	<p>Hammer</p> <ul style="list-style-type: none"> - Auxiliary tool for adjusting or in combination with chisel for punching large holes 	
	<p>Chisel</p> <ul style="list-style-type: none"> - For splitting various materials - Used for punching large holes 	
	<p>File</p> <ul style="list-style-type: none"> - For deburring cut or sharp edges or holes - For adapting components that are matched to each other - Angle grinder is the preferred choice 	
	<p>Thread cutter</p> <ul style="list-style-type: none"> - For cutting threads 	<ul style="list-style-type: none"> - A lot of lubricating oil must be used during operation
	<p>Elbow</p> <ul style="list-style-type: none"> - For aligning the 90-degree angle 	<ul style="list-style-type: none"> - For angles larger or smaller than 90°, these are indicated separately
	<p>Welding</p> <ul style="list-style-type: none"> - Possible welding methods: - MAG – metal welding with active gases - electrode welding (E-Hand) 	<ul style="list-style-type: none"> - Spot welding (also known as tack welding) Small welding spots must be applied to align and fix the components - fixed welding - welding seams 30-60mm and alternate welding and let cool down in between
	<p>Lubricating oil</p> <ul style="list-style-type: none"> - For use with mechanically moving components and for drilling - Reduces friction and wear 	
	<p>Silicone</p> <ul style="list-style-type: none"> - Serves as rust protection 	
	<p>Screw Clamp</p> <ul style="list-style-type: none"> - Used for temporary fixation of components 	
	<p>Paint</p> <ul style="list-style-type: none"> - To protect against rust and improve the design of the product 	<p>The entire system must be painted to protect against rust</p>
	<p>Riveting</p> <ul style="list-style-type: none"> - Riveting is a joining process, especially for sheet metal and similar low strength materials. 	<p>The following equation must be observed to select the correct shaft length: Shaft length = total thickness of the materials to be riveted + 1.5 * shaft diameter.</p>

Table 3 – Symbols and dimensions of the construction manual

Manufacturing process

Adhesive bonding

Gluing of PVC plastic pipes and fittings of the pump is done with PVC-U adhesive and is called swelling welding, among others. Before bonding, the surfaces must be cleaned. The contact surfaces are loosened by the adhesive. They swell and fuse together during the drying process. After gluing, the parts are inseparably connected. The glued surfaces are tight and have the same properties as the original material.

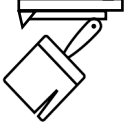
For gluing PVC-U pipes and fittings, the cut pipes or the machined areas on the fittings must first be deburred and provided with a chamfer. Then the PVC-U fitting is pushed onto the pipe at the marked position. The ends of the contact surface between fitting and pipe are marked with a pen to indicate the insertion depth. The adhesive surfaces are degreased with a cloth and PVC cleaner to remove residues of release agents, dirt and grease. Then the PVC adhesive is applied to the contact surface with a flat brush with hard bristles (no brush with plastic hairs). The end of the pipe should be generously coated with adhesive. The contact surface in the fitting is also coated with the adhesive. Here, however, it should be applied only thinly to avoid a large adhesive bulge inside. After coating with the adhesive, the parts are put together. The resulting adhesive bead is removed with a cloth. The glue must dry for at least 24 hours and should not be subjected to wet and mechanical stress. In addition, the bonding should only be carried out in well-ventilated rooms, as the unhealthy solvent will outgas during the drying process.

Screws

Screws must not be tightened more than the permitted torque. Torque wrenches are available for this. Without a torque wrench, the screws must be tightened sensitively and under no circumstances too much.

Table 4 shows the tightening torque for standard threads. The strength class of a screw - for example 8.8 - is indicated on the screw head. If this is not the case, the screw is not approved for machine construction and steel construction. An M10 screw of quality 8.8 must be tightened to approx. 49Nm. Deviations up and down must not be greater than 15%. The screws and nuts used in these building instructions are intended for quality class of 8.8.

Thread size	Tightening torque/tightening torque for standard threads in [Nm]					
Strength class	4.6	5.6	6.8	8.8	10.9	12.9
M6	3.84	4.8	7.69	10.25	14.41	17.29
M7	5.13	6.42	10.27	13.70	19.25	23.1
M8	9.35	11.69	18.7	24.93	35.06	42.07
M10	18	23	37	49	70	83
M12	32	40	65	86	121	146
M14	52	65	104	138	194	233
M16	81	101	161	215	302	363
M18	112	139	222	296	417	500
M20	157	197	315	420	590	709

Table 4 – Tightening torque for standard threads

Drilling

When drilling, the speed of the drill is decisive. Depending on the material and diameter of the drill, this speed must be set on the drill in advance. The resulting chip can be removed cleanly and evenly. Table 5 lists the speed for the material and diameter of the drills. The listed values apply to High Speed Steel (HSS) twist drills. When countersinking with a countersink, a speed corresponding to a drill bit of 20 mm is used for all materials.

	Wood	Steel	Aluminium	Brass	Plastic
Drill	Speeds of rotation in revolutions per minute [rpm]				
4 mm	2600	1800	4000	3000	1400
5 mm	2150	1500	3500	2600	1150
6 mm	1800	1200	3000	2200	950
7 mm	1400	1000	2500	1800	750
8 mm	1100	800	2000	1450	600
10 mm	650	500	1200	900	350
12 mm	500	400	900	700	300
16 mm	300	300	580	400	220
20 mm	260	250	440	310	190
25 mm	250	240	400	300	170

Table 5 – Speeds during drills

TRAINING WORKSHOP (approx. 5 training places)

Here we have compiled a LUXURY tool list for a completely new training metal workshop for the production of many KUKATE units.

ATTENTION:

Over 90% of the costs are investment material for a metal workshop and will last "forever". Only very little of it (e.g. paint and sandpaper) is "consumed" for the construction.

Some tools are desirable for optimal production - but not necessary.

With this tool kit, many OPEN-WIND KUKATE systems can be built. Only the consumable material must be supplemented accordingly.

The amount of gas for welding and the amount of welding wire or coated welding electrodes is not listed here and must still be determined.